



AVAILABLE
2,958 SF

AVAILABLE
1,261 SF

AVAILABLE
1,238 SF

VENTURE VICTORY SHOPS AT FLOWER MOUND

FOR LEASE

214.378.1212

NEC FLOWER MOUND RD & MORRISS RD
FLOWER MOUND, TX

NATALIA SINGER
NSINGER@VENTUREDWF.COM

AMY PJETROVIC
APJETROVIC@VENTUREDWF.COM

MIA UREÑA
MURENA@VENTUREDWF.COM

LOCATION

NEC FLOWER MOUND RD & MORRISS RD

AVAILABLE SPACES

SUITE 190
2,958 SF FORMER CLEANERS

SUITE 150
1,261 SF 2ND GEN RETAIL

SUITE 145
1,238 SF

TRAFFIC COUNTS

FLOWER MOUND RD **MORRISS RD**
17,897 VPD 2023 20,539 VPD 2023

PROPERTY HIGHLIGHTS

- ★ EXCELLENT VISIBILITY FROM THE INTERSECTION
- ★ ACROSS THE STREET FROM KROGER
- ★ GREAT DENSITY: OVER 99,000 PEOPLE IN 3-MILE RADIUS
- ★ DOWN THE STREET FROM 100,000 SF COMMUNITY ACTIVITY CENTER OF FLOWER MOUND

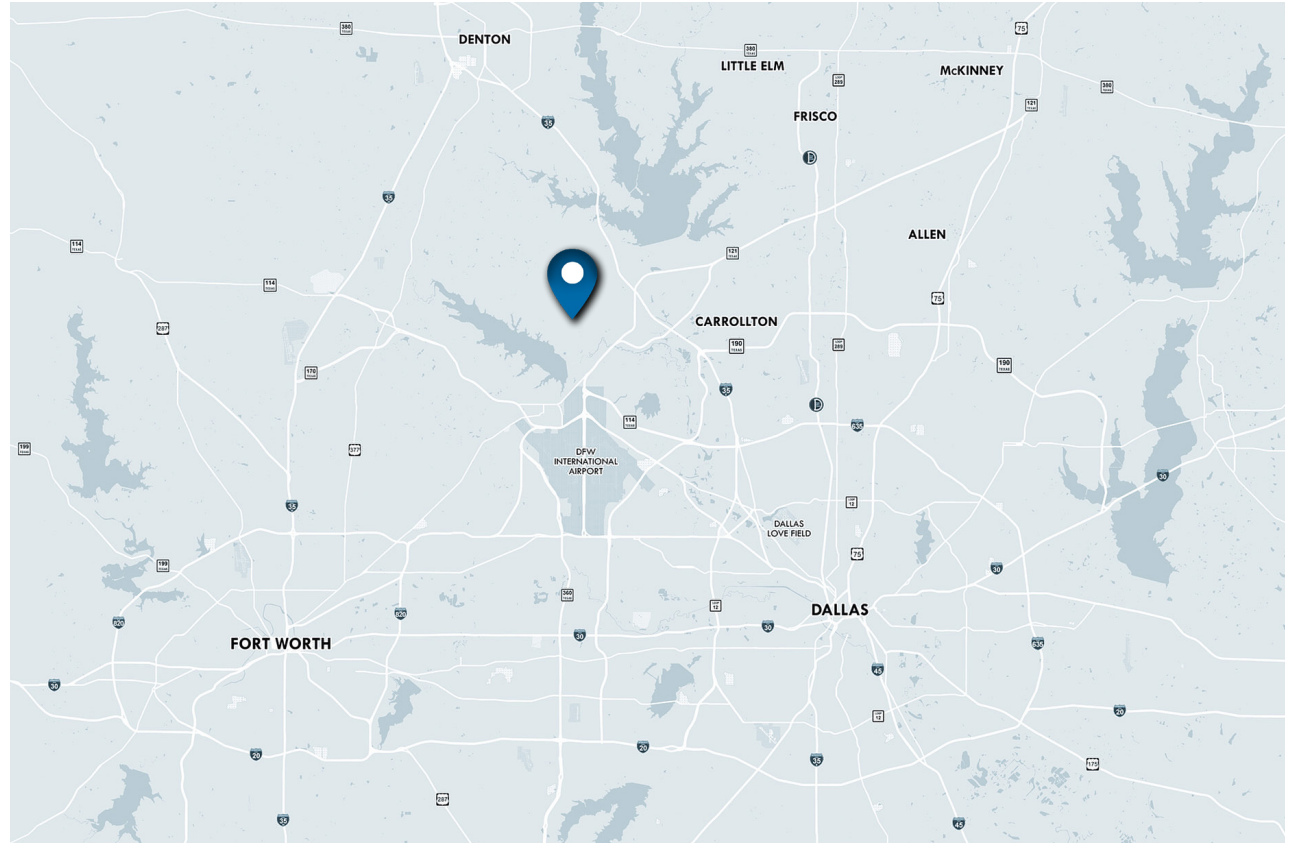

2024 DEMOGRAPHIC SUMMARY

	1 MILE	3 MILES	5 MILES
EST. POPULATION	12,447	99,363	223,206
EST. DAYTIME POPULATION	2,395	33,737	100,783
EST. AVG. HH INCOME	\$188,585	\$148,328	\$155,960

AREA ATTRactions





2,958 SF

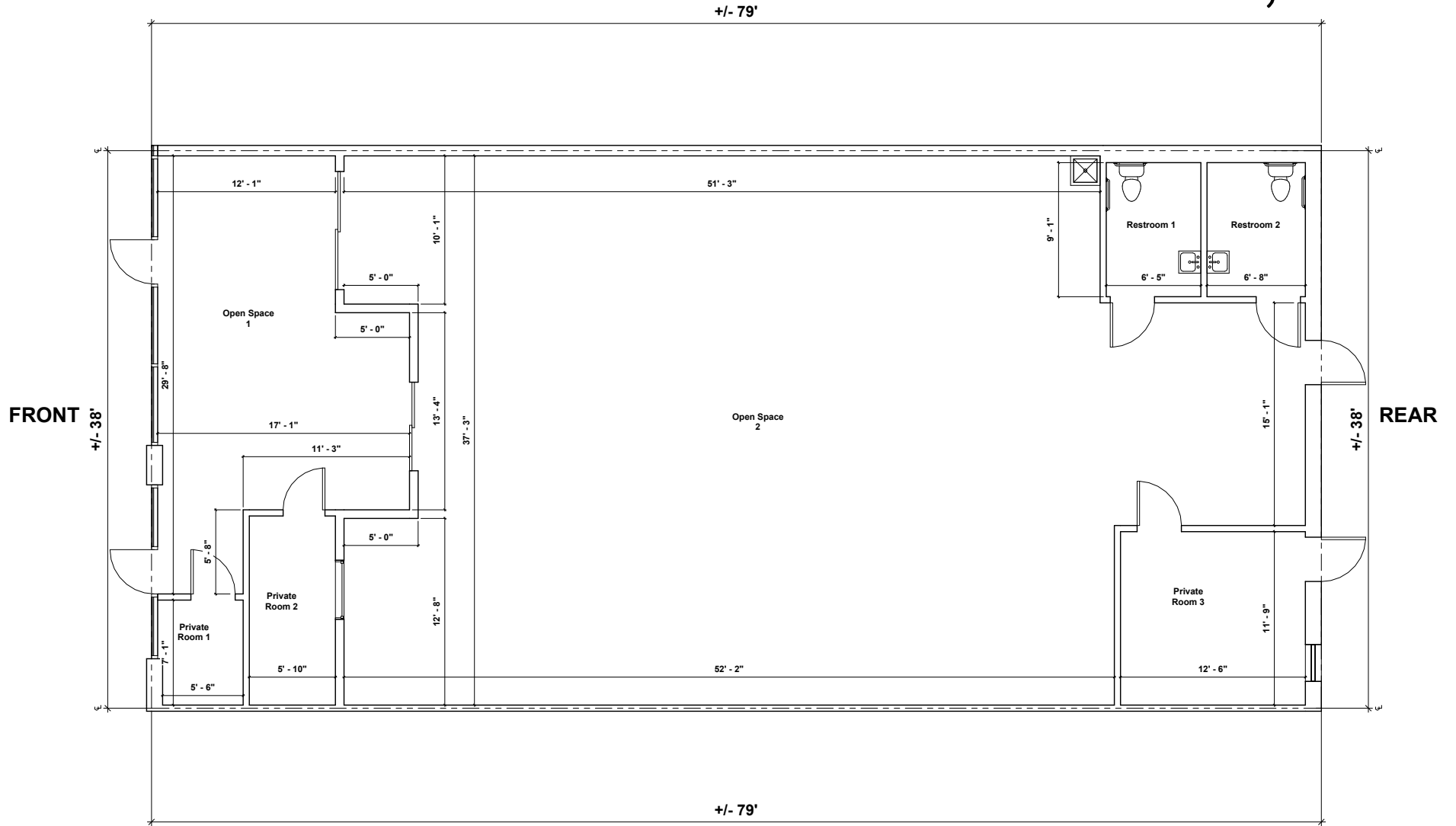

1,261 SF

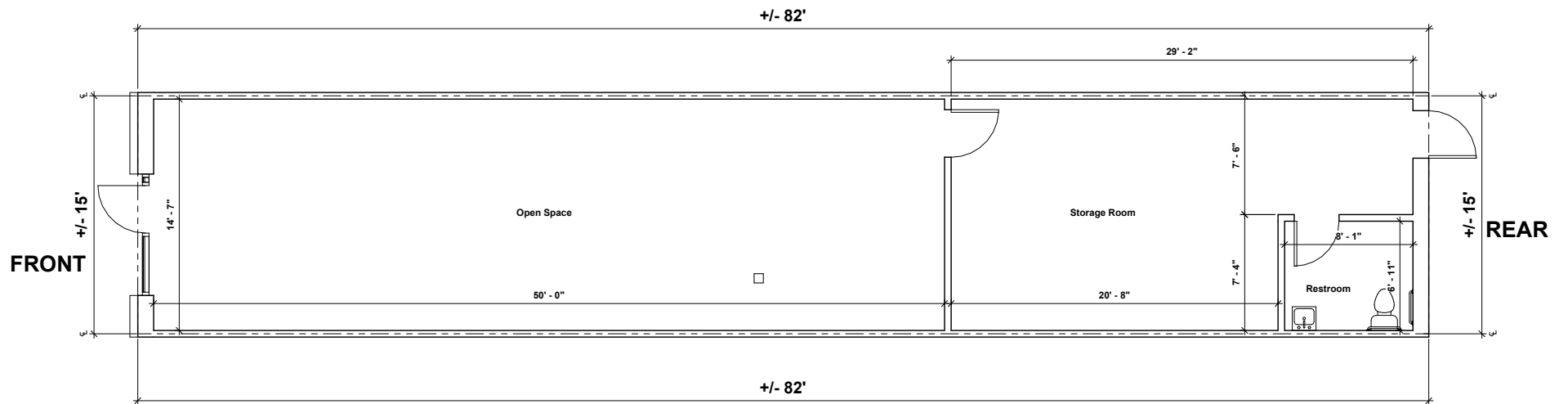

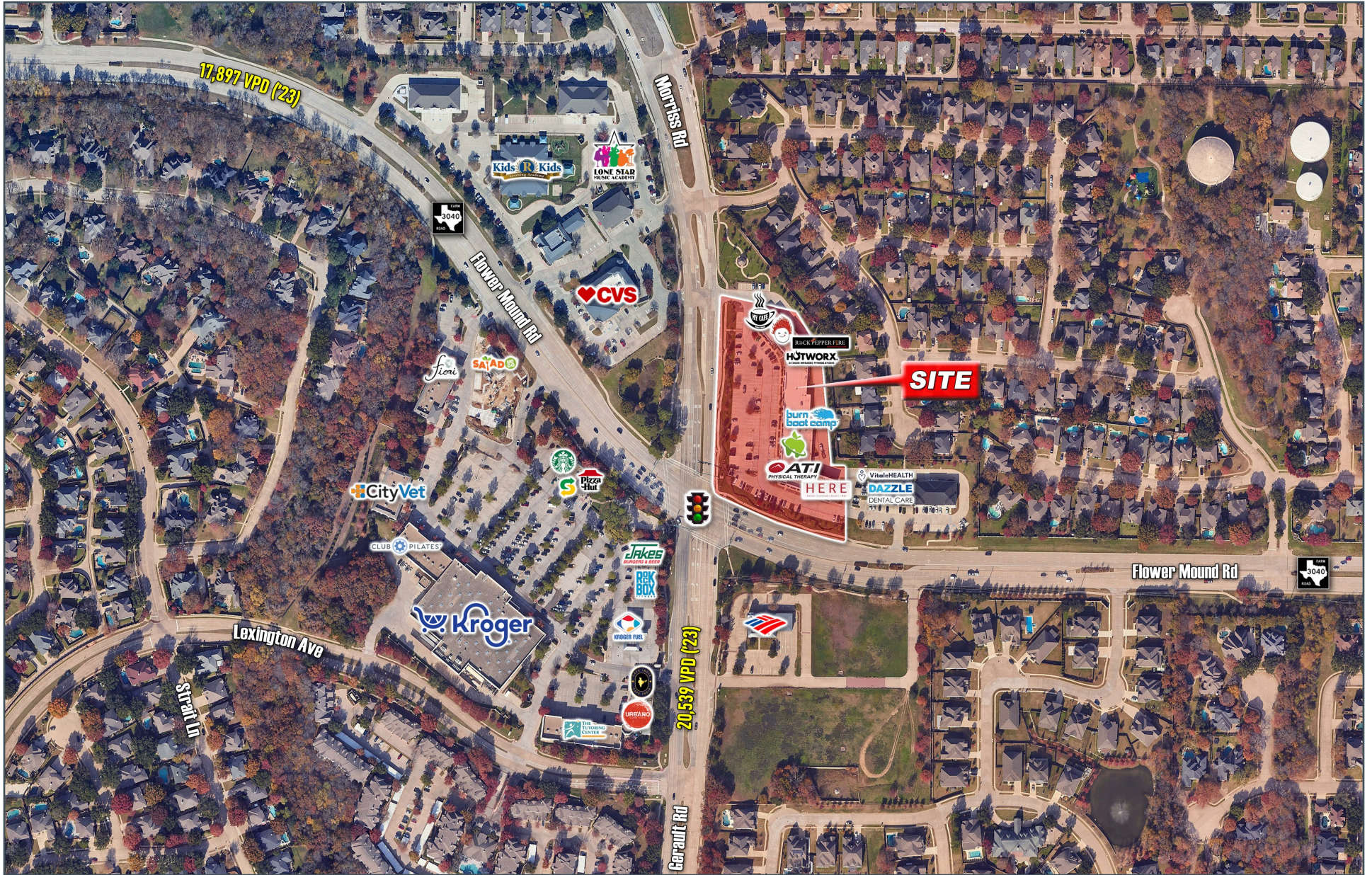

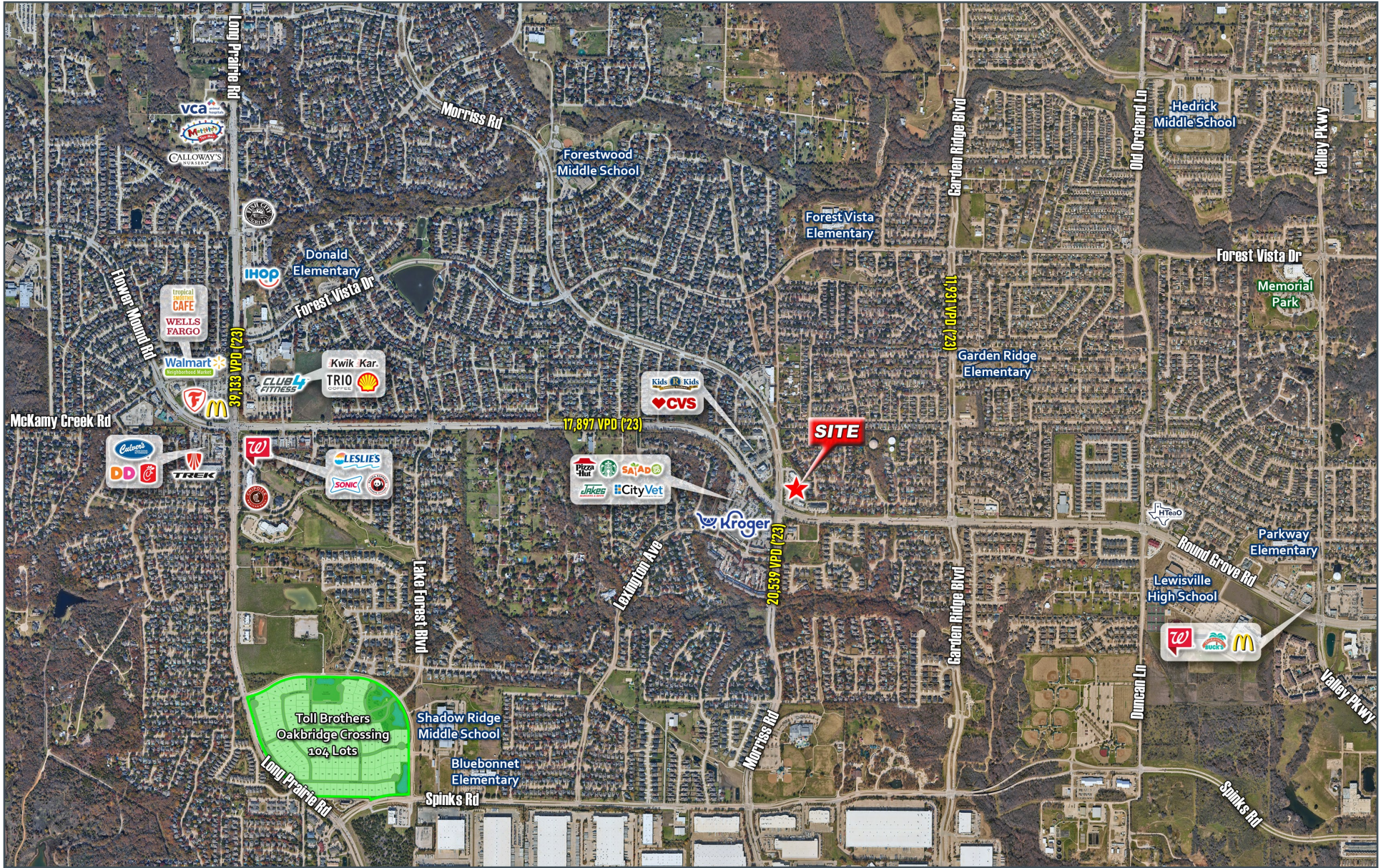





8235 DOUGLAS AVE
SUITE 720
DALLAS, TEXAS 75225
T 214.378.1212
VENTUREDFW.COM

NATALIA SINGER

Senior Vice President
214.378.1212
nsinger@venturedfw.com

AMY PJETROVIC

Principal
214.378.1212
apjetrovic@venturedfw.com

MIA UREÑA

Transaction Manager
214.378.1212
murena@venturedfw.com



Information About Brokerage Services

Texas law requires all real estate license holders to give the following information about brokerage services to prospective buyers, tenants, sellers and landlords.

TYPES OF REAL ESTATE LICENSE HOLDERS:

- **A BROKER** is responsible for all brokerage activities, including acts performed by sales agents sponsored by the broker.
- **A SALES AGENT** must be supervised by a broker to perform any services and works with clients on behalf of the broker.

A BROKER'S MINIMUM DUTIES REQUIRED BY LAW (A client is the person or party that the broker represents):

- Put the interests of the client above all others, including the broker's own interests;
- Inform the client of any material information about the property or transaction received by the broker;
- Answer the client's questions and present any offer to or counter-offer from the client; and
- Treat all parties to a real estate transaction honestly and fairly.

A LICENSE HOLDER CAN REPRESENT A PARTY IN A REAL ESTATE TRANSACTION:

- **AS AGENT OR SUBAGENT FOR OWNER (SELLER/LANDLORD):** The broker becomes the property owner's agent through an agreement with the owner, usually in a written listing to sell or property management agreement. A subagent represents the owner, not the buyer, through an agreement with the owner's broker. An owner's agent must perform the broker's minimum duties above and must inform the owner of any material information about the property or transaction known by the agent, including information disclosed to the agent or subagent by the buyer or buyer's agent.
- **AS AGENT FOR BUYER/TENANT:** The broker becomes the buyer/tenant's agent by agreeing to represent the buyer, usually through a written representation agreement. A buyer's agent must perform the broker's minimum duties above and must inform the buyer of any material information about the property or transaction known by the agent, including information disclosed to the agent by the seller or seller's agent.
- **AS AGENT FOR BOTH – INTERMEDIARY:** To act as an intermediary between the parties the broker must first obtain the written agreement of *each party* to the transaction. The written agreement must state who will pay the broker and, in conspicuous bold or underlined print, set forth the broker's obligations as an intermediary. A broker who acts as an intermediary:
 - Must treat all parties to the transaction impartially and fairly;
 - May, with the parties' written consent, appoint a different license holder associated with the broker to each party (owner and buyer) to communicate with, provide opinions and advice to, and carry out the instructions of each party to the transaction.
 - Must not, unless specifically authorized in writing to do so by the party, disclose:
 - That the owner will accept a price less than the written asking price;
 - That the buyer/tenant will pay a price greater than the price submitted in a written offer; and
 - any confidential information or any other information that a party specifically instructs the broker in writing not to disclose, unless required to do so by law.

TO AVOID DISPUTES, ALL AGREEMENTS BETWEEN YOU AND A BROKER SHOULD BE IN WRITING AND CLEARLY ESTABLISH:

- The broker's duties and responsibilities to you, and your obligations under the representation agreement.
- Who will pay the broker for services provided to you, when payment will be made and how the payment will be calculated.

LICENSE HOLDER CONTACT INFORMATION: This notice is being provided for information purposes. It does not create an obligation for you to use the broker's services. Please acknowledge receipt of this notice below and retain a copy for your records.

Venture Commercial Real Estate, LLC	476641	info@venturedfw.com	214-378-1212
Broker's Licensed Name or Primary Assumed Business Name	License No.	Email	Phone
Michael E. Geisler	350982	mgeisler@venturedfw.com	214-378-1212
Designated Broker's Name	License No.	Email	Phone
XXXXXXXXXXXXXXXXXXXXXXXXXXXX	XXXXXXXXXXXX	XXXXXXXXXXXXXXXXXXXXXXXXXXXX	XXXXXXXXXXXX
Agent's Supervisor's Name	License No.	Email	Phone
Natalia Singer	617025	nsinger@venturedfw.com	214-378-1212
Sales Agent/Associate's Name	License No.	Email	Phone

Buyer/Tenant/Seller/Landlord Initials

Date



Information About Brokerage Services

Texas law requires all real estate license holders to give the following information about brokerage services to prospective buyers, tenants, sellers and landlords.

TYPES OF REAL ESTATE LICENSE HOLDERS:

- **A BROKER** is responsible for all brokerage activities, including acts performed by sales agents sponsored by the broker.
- **A SALES AGENT** must be supervised by a broker to perform any services and works with clients on behalf of the broker.

A BROKER’S MINIMUM DUTIES REQUIRED BY LAW (A client is the person or party that the broker represents):

- Put the interests of the client above all others, including the broker’s own interests;
- Inform the client of any material information about the property or transaction received by the broker;
- Answer the client’s questions and present any offer to or counter-offer from the client; and
- Treat all parties to a real estate transaction honestly and fairly.

A LICENSE HOLDER CAN REPRESENT A PARTY IN A REAL ESTATE TRANSACTION:

- **AS AGENT OR SUBAGENT FOR OWNER (SELLER/LANDLORD):** The broker becomes the property owner’s agent through an agreement with the owner, usually in a written listing to sell or property management agreement. A subagent represents the owner, not the buyer, through an agreement with the owner’s broker. An owner’s agent must perform the broker’s minimum duties above and must inform the owner of any material information about the property or transaction known by the agent, including information disclosed to the agent or subagent by the buyer or buyer’s agent.
- **AS AGENT FOR BUYER/TENANT:** The broker becomes the buyer/tenant’s agent by agreeing to represent the buyer, usually through a written representation agreement. A buyer’s agent must perform the broker’s minimum duties above and must inform the buyer of any material information about the property or transaction known by the agent, including information disclosed to the agent by the seller or seller’s agent.
- **AS AGENT FOR BOTH – INTERMEDIARY:** To act as an intermediary between the parties the broker must first obtain the written agreement of *each party* to the transaction. The written agreement must state who will pay the broker and, in conspicuous bold or underlined print, set forth the broker’s obligations as an intermediary. A broker who acts as an intermediary:
 - Must treat all parties to the transaction impartially and fairly;
 - May, with the parties’ written consent, appoint a different license holder associated with the broker to each party (owner and buyer) to communicate with, provide opinions and advice to, and carry out the instructions of each party to the transaction.
 - Must not, unless specifically authorized in writing to do so by the party, disclose:
 - That the owner will accept a price less than the written asking price;
 - That the buyer/tenant will pay a price greater than the price submitted in a written offer; and
 - any confidential information or any other information that a party specifically instructs the broker in writing not to disclose, unless required to do so by law.

TO AVOID DISPUTES, ALL AGREEMENTS BETWEEN YOU AND A BROKER SHOULD BE IN WRITING AND CLEARLY ESTABLISH:

- The broker’s duties and responsibilities to you, and your obligations under the representation agreement.
- Who will pay the broker for services provided to you, when payment will be made and how the payment will be calculated.

LICENSE HOLDER CONTACT INFORMATION: This notice is being provided for information purposes. It does not create an obligation for you to use the broker’s services. Please acknowledge receipt of this notice below and retain a copy for your records.

Venture Commercial Real Estate, LLC	476641	info@venturedfw.com	214-378-1212
Broker’s Licensed Name or Primary Assumed Business Name	License No.	Email	Phone
Michael E. Geisler	350982	mgeisler@venturedfw.com	214-378-1212
Designated Broker’s Name	License No.	Email	Phone
XXXXXXXXXXXXXXXXXXXXXXXXXXXX	XXXXXXXXXXXX	XXXXXXXXXXXXXXXXXXXXXXXXXXXX	XXXXXXXXXXXX
Agent’s Supervisor’s Name	License No.	Email	Phone
Amy Pjetrovic	550374	apjetrovic@venturedfw.com	214-378-1212
Sales Agent/Associate’s Name	License No.	Email	Phone

Buyer/Tenant/Seller/Landlord Initials

Date



Information About Brokerage Services

Texas law requires all real estate license holders to give the following information about brokerage services to prospective buyers, tenants, sellers and landlords.

TYPES OF REAL ESTATE LICENSE HOLDERS:

- **A BROKER** is responsible for all brokerage activities, including acts performed by sales agents sponsored by the broker.
- **A SALES AGENT** must be supervised by a broker to perform any services and works with clients on behalf of the broker.

A BROKER'S MINIMUM DUTIES REQUIRED BY LAW (A client is the person or party that the broker represents):

- Put the interests of the client above all others, including the broker's own interests;
- Inform the client of any material information about the property or transaction received by the broker;
- Answer the client's questions and present any offer to or counter-offer from the client; and
- Treat all parties to a real estate transaction honestly and fairly.

A LICENSE HOLDER CAN REPRESENT A PARTY IN A REAL ESTATE TRANSACTION:

- **AS AGENT OR SUBAGENT FOR OWNER (SELLER/LANDLORD):** The broker becomes the property owner's agent through an agreement with the owner, usually in a written listing to sell or property management agreement. A subagent represents the owner, not the buyer, through an agreement with the owner's broker. An owner's agent must perform the broker's minimum duties above and must inform the owner of any material information about the property or transaction known by the agent, including information disclosed to the agent or subagent by the buyer or buyer's agent.
- **AS AGENT FOR BUYER/TENANT:** The broker becomes the buyer/tenant's agent by agreeing to represent the buyer, usually through a written representation agreement. A buyer's agent must perform the broker's minimum duties above and must inform the buyer of any material information about the property or transaction known by the agent, including information disclosed to the agent by the seller or seller's agent.
- **AS AGENT FOR BOTH – INTERMEDIARY:** To act as an intermediary between the parties the broker must first obtain the written agreement of *each party* to the transaction. The written agreement must state who will pay the broker and, in conspicuous bold or underlined print, set forth the broker's obligations as an intermediary. A broker who acts as an intermediary:
 - Must treat all parties to the transaction impartially and fairly;
 - May, with the parties' written consent, appoint a different license holder associated with the broker to each party (owner and buyer) to communicate with, provide opinions and advice to, and carry out the instructions of each party to the transaction.
 - Must not, unless specifically authorized in writing to do so by the party, disclose:
 - That the owner will accept a price less than the written asking price;
 - That the buyer/tenant will pay a price greater than the price submitted in a written offer; and
 - any confidential information or any other information that a party specifically instructs the broker in writing not to disclose, unless required to do so by law.

TO AVOID DISPUTES, ALL AGREEMENTS BETWEEN YOU AND A BROKER SHOULD BE IN WRITING AND CLEARLY ESTABLISH:

- The broker's duties and responsibilities to you, and your obligations under the representation agreement.
- Who will pay the broker for services provided to you, when payment will be made and how the payment will be calculated.

LICENSE HOLDER CONTACT INFORMATION: This notice is being provided for information purposes. It does not create an obligation for you to use the broker's services. Please acknowledge receipt of this notice below and retain a copy for your records.

Venture Commercial Real Estate, LLC	476641	info@venturedfw.com	214-378-1212
Broker's Licensed Name or Primary Assumed Business Name	License No.	Email	Phone
Michael E. Geisler	350982	mgeisler@venturedfw.com	214-378-1212
Designated Broker's Name	License No.	Email	Phone
XXXXXXXXXXXXXXXXXXXXXXXXXXXX	XXXXXXXXXXXX	XXXXXXXXXXXXXXXXXXXXXXXXXXXX	XXXXXXXXXXXX
Agent's Supervisor's Name	License No.	Email	Phone
Mia Ureña	748118	murena@venturedfw.com	214-378-1212
Sales Agent/Associate's Name	License No.	Email	Phone

Buyer/Tenant/Seller/Landlord Initials

Date